

AUSSIE OWNED
MADE AUSSIE
PROUD AUSSIE
TOUGH



DINGO RANGE



1980's



1990's



Early 2000's



Mid 2000's



2010



2017

WHY DINGO?

Dingo remains AUSSIE OWNED and AUSSIE MADE for AUSTRALIAN CONDITIONS. In an industry that has seen foreign imitators come and go as they compromise on quality for price, Dingo has maintained its ongoing commitment to quality; because we understand better than anyone what our Dingo owners need to put their machines through.

HYDRAULIC PERFORMANCE

Dingo is a 'hydraulic power plant on wheels'. Designed to run high pressure and high flow attachments. Ozzy Dingo models have the best hydraulic power in their class, better than most larger skid steers. When it comes to hydraulics, the engine is only a very small player, It is the flow and pressure that is available to the attachment that makes the difference. Nothing beats an OZZY DINGO

SIMPLE AND SOLID LINKAGE SYSTEM

Back in the early 90's Dingo removed the complicated selflevelling system from the design. This reduced the mount plate assembly to 3 joints, (previously 7) reducing the maintenance required as well as the wear and slop associated with the self-levelling system. Self-levellers were designed for large loaders where the operator's vision of the load was often obstructed by the canopy. Not a problem on a Dingo.

LIFT MORE WEIGHT

With excellent weight distribution the weight is down low, the Dingo can lift the heavier loads, enabling bigger buckets to get the job done faster and safer.

CLEANABLE HYDRAULIC TANK

Oil contamination is the greatest enemy of all hydraulic machines. The lid of the Dingo hydraulic tank can be removed to allow thorough cleaning, should contamination occur. This is a "must have" that others choose to ignore.

POWDER COATING

The best machine needs the best finish. Dingos are sand blasted, primed, powder coated and then baked. This produces a harder wearing and a longer lasting finish.

**THE FAMOUS
K94 CHASSIS
WITH GREATER
LIFT HEIGHT
AND STRENGTH
IS NOW
STANDARD
ACROSS THE
RANGE**



**THREE NEW MODELS TO
CHOOSE FROM, ALL
FITTED WITH THE DINGO
MULTI PUMP SYSTEM TO
PROVIDE EFFICIENT
HYDRAULIC POWER**

THIS ALLOWS THE DINGO TO:

- Power both the Dingo and the attachment at the same time without one robbing power from the other.
- Keep the hydraulic oil cooler by only sending the oil to where it needs to go i.e. when trenching the Dingo gets 5% of the oil whilst the trencher gets 95%. This controls the ground speed, maximizes digging power and keeps the oil cool by minimizing the components it has to travel through.
- Give the Dingo up to three drive speeds by the ability to switch the pumps between circuits.
- Infinitely control the division of power between the two circuits to control ground speed (when trenching) and maximize flow to the attachment.
- Have high hydraulic flow and operating pressure.





THE NEXT GENERATION OF DINGO MINI LOADERS

→ **THE
RANGE**

K9-P

K9-D

K9-C

K9-R

Model	K9 Petrol	K9 Diesel	K9 Contractor	K9 Remote
Engine	Kohler EFI Petrol	Yanmar Diesel	Yanmar Diesel	Yanmar Diesel
Power	23hp	27hp	27hp	27hp
Operating Pressure	3200 psi	3200 psi	3400 psi	3200 psi
Hydraulic Pumps	2	2	3	2
Auxiliary Output Circuits	1	2	2	2
Machine Hydraulic Flow	47 L/min	47 L/min	52 L/min	47 L/min
Attachment Hydraulic Flow	47 L/min	47 L/min	52 L/min	47 L/min
Hydraulic Oil Cooler	X	X	✓	X
Wheel Size	20x10.5x8	20x10.5x8	20x10.5x10	20x10.5x8
Weight (no attachment)	862kg	984kg	1080kg	928kg
Tipping Load	650kg	650kg	880kg	650kg
Operating Load (50% of Tip)	325kg	325kg	440kg	325kg
Max Travel Speed	7.5km/h	7.5km/h	9.5km/h	7.5km/h
Fuel Capacity	24L	24L	24L	24L

→ **TYRE
OPTIONS**



SAND FLOATATION



DINGO MULTI PURPOSE



HEAVY DUTY LUG



NARROW ACCESS



TRACK OVER TYRE



SEMI SOLID

→ THE DIMENSIONS

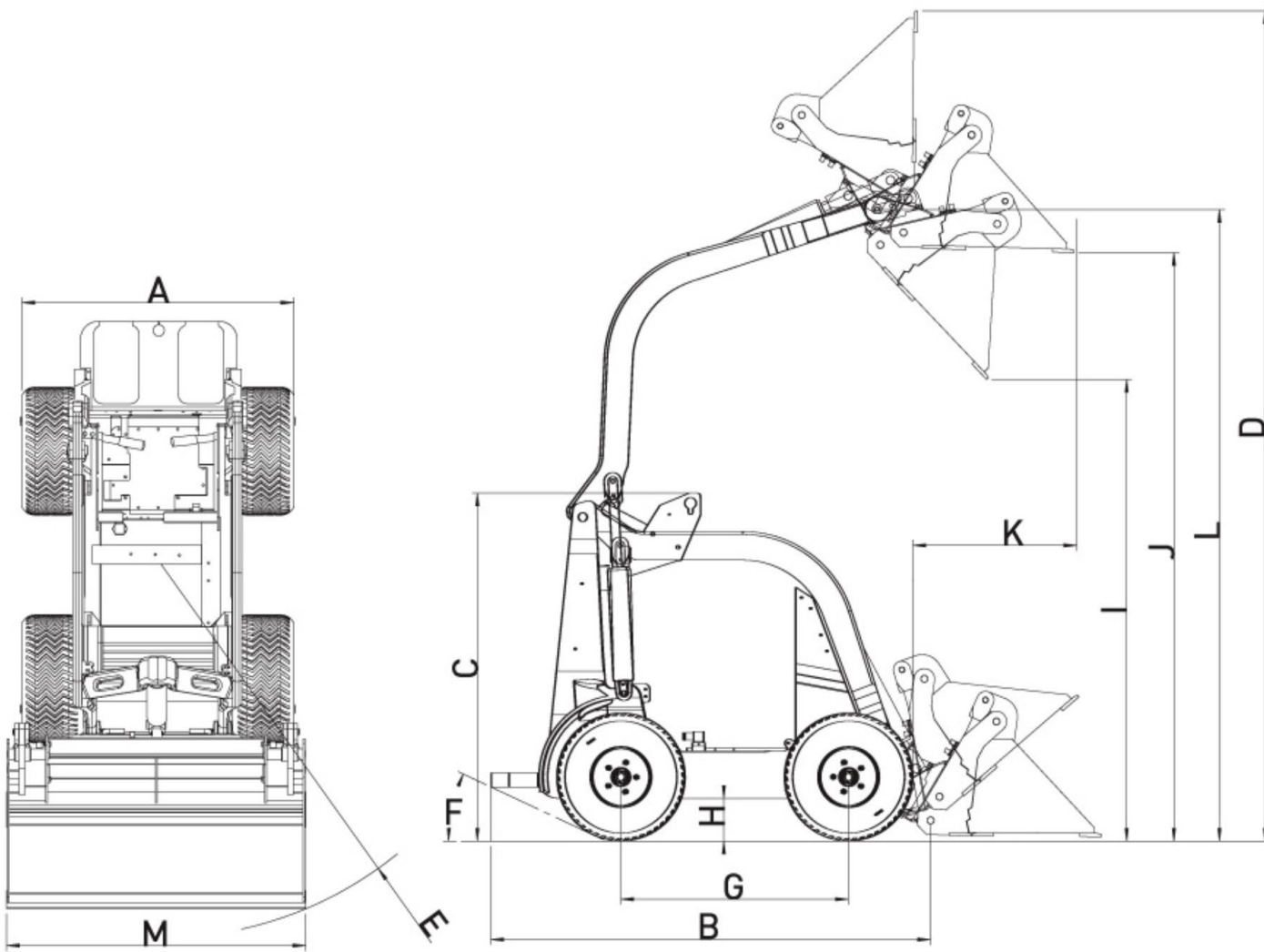

A	1050mm / 850mm
B	1600mm
C	1225mm
D	2675mm
E	1300mm
F	25°
G	800mm
H	170mm
I	1550mm
J	1870mm
K	800mm
L	1985mm
M	1050mm



**THE RIGHT TOOL
FOR THE RIGHT JOB**

→ THE ATTACHMENTS



GP BUCKET



4 IN 1 BUCKET



LEVELLER



RIPPERS



LIFTING JIB



TRENCHER



RAKE BUCKET



POST HOLE AUGER



RAKE GRAB



ROTARY HOE



PALLET FORKS



BUCKET BROOM



DOZER BLADE



STUMP GRINDER



ROCK BREAKER

WALCALAC **DIGRITE** TAKEUCHI

SALES
RECEPTION
ADMINISTRATION

SERVICE
PARTS
REPAIR

DINGO
K9P

READY TO TOW AWAY
DINGO PACKAGES



→ THE PACKAGES

PACKAGES ARE FULLY CUSTOMIZABLE TO SUIT YOUR NEEDS

Model	Beginner	Intermediate	Contractor	Custom
Dingo	K9P	K9D	K9C	OPT
Trailer	Coastmac PT23	Brian James DP27	Brian James DP35	OPT
Bucket	✓	✓	4 in 1	OPT
4 in 1 Bucket	OPT	OPT	✓	OPT
Lifting Jib	✓	✓	✓	OPT
Leveller	✓	✓	✓	OPT
Pallet Forks	OPT	✓	✓	OPT
Rake	OPT	✓	Grapple	OPT
Auger Drive & Augers	OPT	✓	✓	OPT
Chain Trencher	OPT	OPT	✓	OPT
Rake Grapple	OPT	OPT	✓	OPT
Rippers	OPT	OPT	✓	OPT
Bucket Broom	OPT	OPT	OPT	OPT
Other Attachments	OPT	OPT	OPT	OPT

MICALAC

DIGRITE

TRIKELUCHI

→ ADDRESS
**6 BELLOWS ST
WELSHPOOL**

→ PHONE
9358 4333

→ WEB
DIGRITE.COM.AU



**THE HOME OF
DINGO IN THE WEST**